

Sunny Gardens Features and Specifications

Sunny Max Beta (model C5, gen4)

1. Capacity – 66 Plants
2. Dimensions With Wheels – 70H x 52 7/16 W x 26 5/8 D
3. Standard Lights – 36W LED Grow lights x 6 (total)
4. Seedling Light – 18W LED Grow light x 1
5. Main Pump – 1000 GPH
6. Power requirements – 120V
7. Total Power – 364W
8. Max Amps – 3.03 amps
9. Main Water Tank
 - a. Capacity – 23.3 US Gallons
 - b. Useable Capacity – 15.32 US Gallons
10. Weight –
 - a. Shipping – 345lb
 - b. Dry – 280lb
 - c. Running (Full) – 408lb
11. Estimated Cost per Day (@\$0.10/kWh)
Lights on 16hr/day and pumps/fans 24hr/day – \$0.67
12. Exterior – HDPE (80% Recycled)
13. Doors – Tempered glass with HDPE Frame
14. Frame - Aluminum
15. Grow trays – Food grade plastic

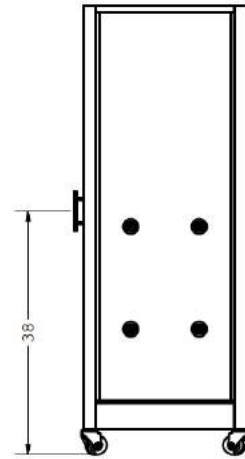

SIDE VIEW

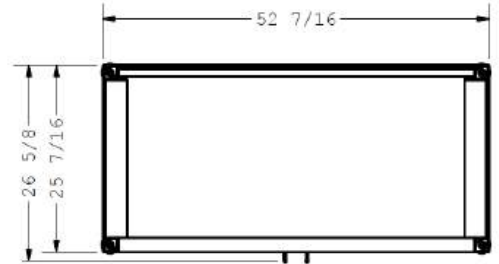

TOP VIEW

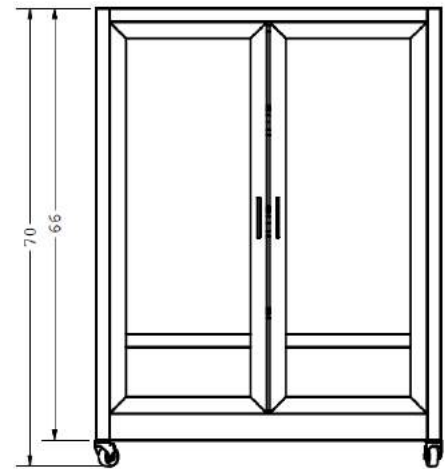

FRONT VIEW

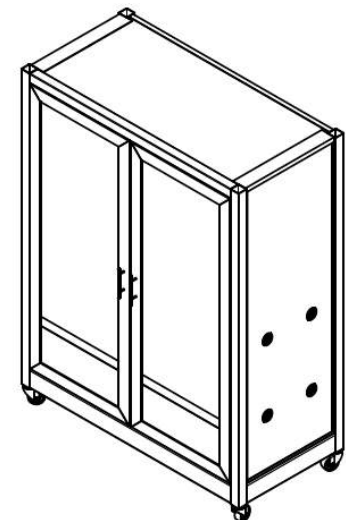

ISO VIEW

Features

Commercial, sturdy construction; Beautiful design, accentuates any space; Capacity of 66 plants; Arrives fully assembled; Plug and grow turnkey garden; Only \$1/day to run; Easy cleaning; Low maintenance; Casters (wheels) for easy movement; Tempered glass doors for safety and durability; Programmable timer for lights, fans and pumps; Separate seedling area for better germination rates; Ability to grow a large variety of vegetables; True gardening experience; Low environmental impact; Made in the USA with recycled materials; Supports American manufacturing